

# SCHOTT PYRAN® S

## Fire Resistant Structural Glazing System

### 30 minutes integrity

Traditional fire rated structural glazing systems require mullion and transom constructions which can be obtrusive and detract from the natural transparency of glass. As a result, architects and designers have to compromise their designs where fire protection is necessary.

This no longer has to be the case as proven by the innovative PYRAN® S Structural Glazing System from SCHOTT.

### The Concept

The SCHOTT Structural Glazing System offers a frameless construction supported by steelwork behind the glass facade and a series of brackets. The joints between the PYRAN® S glass panels are filled with Fireglaze intumescent compound from Sealmaster Ltd.

The glass panes may be connected in portrait or landscape format in maximum dimensions up to 1200 mm x 3000 mm.

The panes are fixed back to the supporting steelwork with special fixings and brackets.

- Under normal construction conditions the point support fixings carry the full weight of the glass panes without creating any additional stresses on the drilled area of the glass.
- Even during extreme movements caused in a fire situation the point support fixings provide pressure free support of the glass.

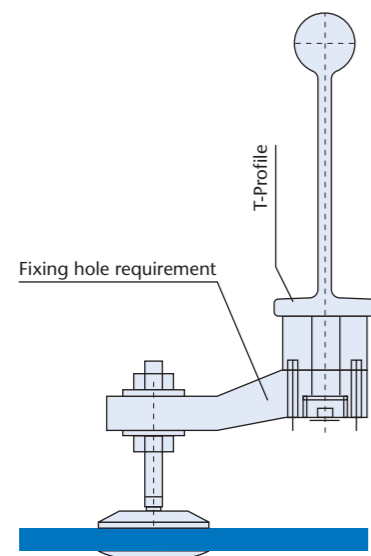

### System components

#### T-Profiles:

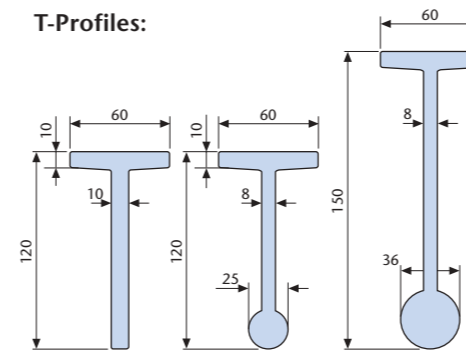

These T-Profiles are typical of the support steelwork.

#### Point support fixings:

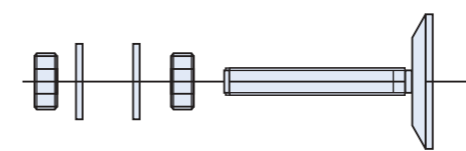

#### Stainless steel brackets

The connection of the brackets to the glass is designed in such a way that no excessive movement can occur. Ball joints in the point assembly allow for full deflection of the glass panes during exposure to positive and negative air pressures. A combination of fixed and moveable attachment points within each bracket allows independent movement between the support construction and the glazing. The glass panes are hung from the upper holes and then securely fixed at one corner so that movement is taken up by the remaining fixings.

#### Fixing hole requirements:

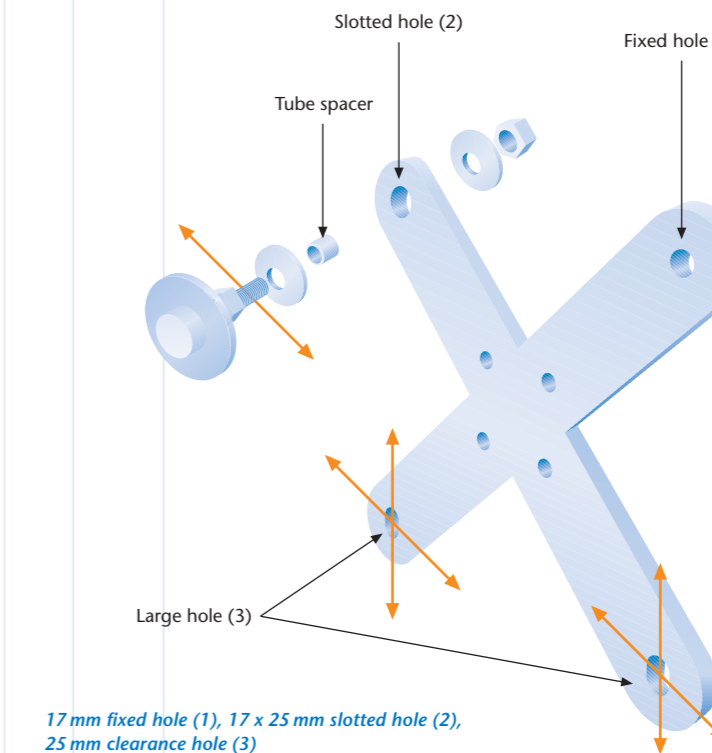

17 mm fixed hole (1), 17 x 25 mm slotted hole (2), 25 mm clearance hole (3)



Typical cross section

With this innovation SCHOTT is responding to the demands of 21st century architecture by making glass even more versatile. It is now possible to design partitions and atria walling incorporating fire resistant glass with this exciting development.